

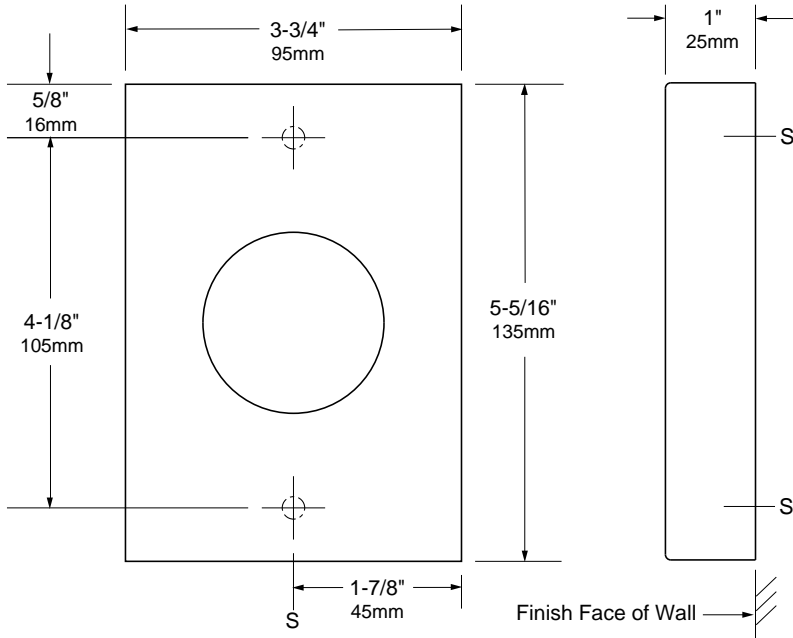

Technical Data

SURFACE-MOUNTED SANITARY DISPOSAL BAG DISPENSER

B-3541



MATERIALS:

Cover – 18-8 S, type-304, 22-gauge (0.8mm) stainless steel with satin finish.

Wall Plate – 18-8 S, type-304, 22-gauge (0.8mm) stainless steel.

OPERATION:

Sanitary disposal bag pulls out. Cover snaps off for filling. Capacity: one sanitary disposal box.

INSTALLATION:

For partitions with particle-board or other solid core, secure with two #8 x 1/2" (M4.2 x 12.5mm) sheet-metal screws (not furnished) at all points indicated by an S, or provide through-bolts, nuts, and washers.

For hollow-core metal partitions, provide solid backing into which sheet-metal screws can be secured. If two units are installed back-to-back, then provide threaded sleeves and machine screws for the full thickness of partition.

For masonry walls, provide fiber plugs or expansion shields for use with sheet-metal screws, or provide 3/16" (5mm) toggle bolts or expansion bolts.

For plaster or dry wall construction, provide concealed backing to comply with local building codes, then secure unit with sheet-metal screws.

SPECIFICATION:

Surface-mounted sanitary disposal bag dispenser shall be type-304 stainless steel. Exposed surfaces shall have satin finish. Cover shall snap off wall plate for refilling. Unit shall have a capacity of one sanitary disposal bag box.

Surface-Mounted Sanitary Disposal Bag Dispenser shall be Model B-3541 of Bobrick Washroom Equipment, Inc. Clifton Park, New York; Jackson, Tennessee; Los Angeles, California; Bobrick Washroom Equipment Company, Scarborough Ontario; Bobrick Washroom Equipment Pty. Ltd., Australia; and Bobrick Washroom Equipment Limited, United Kingdom.